

High Pressure Regulator up to 414 bar

RH4

Description	High pressure regulator with balanced valve design ensuring stable downstream pressure. Excellent for low pressure.		
Media	compressed air, non-corrosive gases or liquids		
Supply pressure	max. 414 bar		
Exhaust	for compressed air or gases: 1/4" NPT tapped exhaust for inlet and outlet		
Leakage	bubble-tight		
Adjustment	by black plastic knob, optionally pneumatical control through diaphragm or piston		
Relieving function	for compressed air or gases: relieving for liquids: non-relieving		
Gauge port	non, optionally 1/4" NPT for inlet and outlet		
Mounting position	any		
Temperature range	-26 °C to 74 °C / -15 °F to 165 °F		
Weight	2.2 kg		
Material	Body: brass, optionally 316 stainless steel	O-rings: NBR/Buna-N, on request FKM, Kalrez, E.P.	
	Main valve seat: Vespel SP21	Relieving valve: Vespel SP21	
	Inner valve: Monel, stainless steel	Filter: bronze, 40 µm, only for liquids	

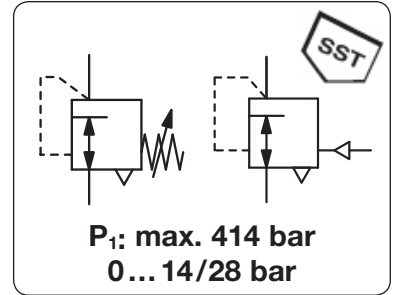

Dimensions			K _v -value	Flow rate		Connection thread	Pressure range	Order number
A	B	C	(m ³ /h)	m ³ /h*1	l/min*1	NPT	bar	
mm	mm	mm						

High pressure regulator 414 bar								brass body, Vespel SP21, NBR/Buna-N relieving, without gauge port	RH4
76	159	19	0.3	510	8500	3/8" NPT	0 ... 14	RH4-03A	
							0 ... 28	RH4-03B	
						1/2" NPT	0 ... 14	RH4-04A	
							0 ... 28	RH4-04B	



RH4

Special options, add the appropriate letter

booster version	1/2" NPT, 0...41 bar, brass, diaphragm control, P _{St.} = 5.8 bar	RH4-04J1
	piston control	RH4-04J2
non-relieving	without relieving function	RH4-0 . .K
stainless steel body		RH4-0 . .S
gauge port	1/4" NPT for inlet and outlet	RH4-0 . .M
brass pressure gauge	inlet side HM	outlet side RH4-0 . .MGM
SST pressure gauge	inlet side H	outlet side RH4-0 . .MG

Accessories

mounting nut for panel mounting **62634**

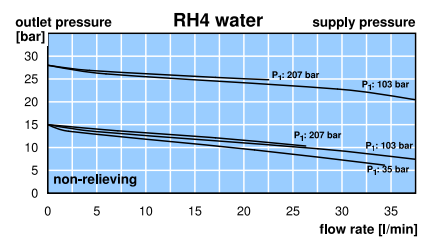
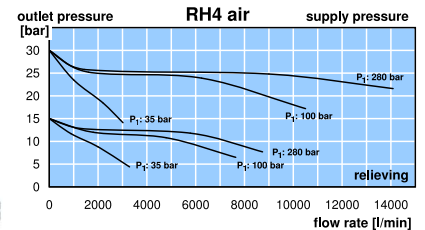
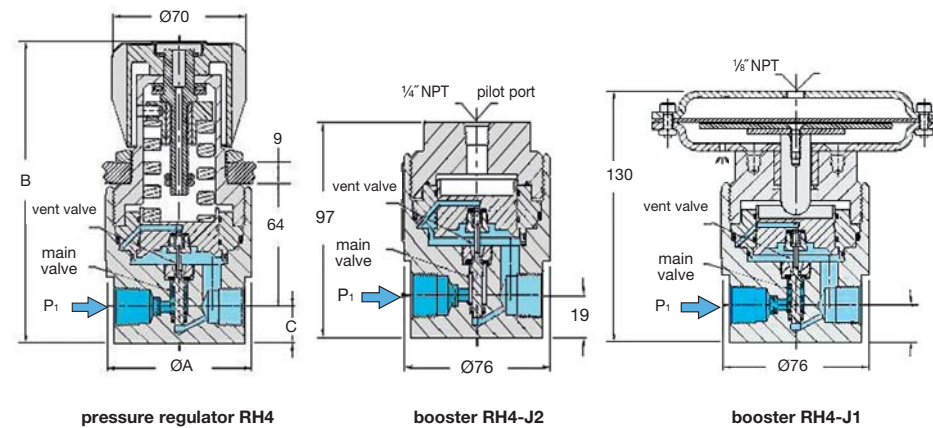
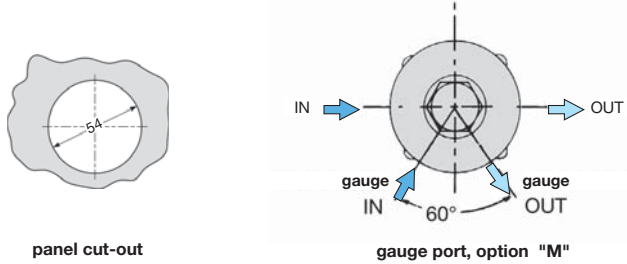

*1 at 280 bar supply pressure and 14 bar outlet pressure

PDF CAD
www.aircom.net

Order example:
RH4-03A